



VULCANIZING PRESSES



SVP

SECTIONAL VULCANIZING PRESS WITH (E-STYLE) BARS

The **SVP** from ALMEX is the world's preferred heavyweight sectional vulcanizing press. Offering portability and great size versatility for coverage of all splice lengths, whether fabric ply or steel cord belt. These presses disassemble into individual components for ease of transport and maneuverability when splicing in cramped or remote locations. Components are lightweight and easy to assemble. The modular design also allows for an increase in splice length or belt width by adding another section.

FEATURES:

- Signature Almix "Pressure Bag" uniform pressure system
- Custom "Extruded Plank" cooling system within platens
- Durable "Silicone Element" heating system, custom designed to voltage phase and cycle
- Exceptional remote digital control
- Accurate temperature control and indication
- Operating pressures of 7 bar (100psi) to 14 bar (200psi)
- Various Control options available including ground fault and ground continuity monitoring

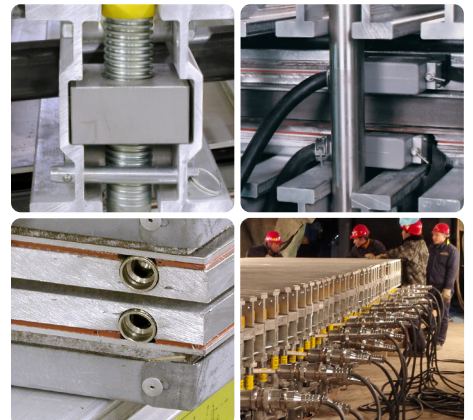

AVAILABLE ACCESSORIES:

- T6 Series Control Boxes
- SG1 Multi-Press Control Box
- Cooling and Pressure Tanks
- Personalized Wraps



Control Accessories



SVP Sectional Vulcanizing Press

PRODUCT SPECIFICATIONS:

PLATENS

- Each sectional press is constructed with aluminum flexible platens that contour to the conveyor belt surface during splicing
- Platens are individually designed and include extruded plank, silicone heating elements (up to 163 °C/325 °F), and durable composite insulating packaging
- Sturdy electrical connectors and moisture-proof latch enhance press durability

FRAME

- Bars are available in various profiles and lengths to provide a custom solution for your needs
- Bars are specially designed for ALMEX SVPs and manufactured out of quality extruded aluminum
- Various bolt and nut styles complement each bar type and provide a secure, pressurized splice

CONTROL BOX

SUITABLE CONTROLS:

- T6 (all models) • SG1

GROUND FAULT:

- T4-GF1 (BOTE) • T4-GF2 (BOTE) • T4P-GF1 (AS/NZS)
- T4P-GFIU (AS/NZS) • T6GFXP

PRESSURE, COOLING

- Pneumatic pressure up to 100 psi or with fluid pressure pump up to 200 psi

SUITABLE PUMPS:

- HP25MAX • HPP20-4 • HPPC20-4
- The pumps include gauges for fluid level and pressure
- Extra reservoirs can be easily added for larger presses
- Cooling options are also available



SVP Sectional Vulcanizing Press

PRODUCT SPECIFICATIONS:

The proper model selection for a SECTIONAL vulcanizer depends on determining dimensions A and B (see diagram at right).

A – the platen length (A) is calculated by adding to the belt manufacturer’s recommended splice length

- 6 inches (150 mm) for fabric belt
- 14 inches (355 mm) for steelcord belt

B – the platen width (B) which includes the bias angle, is determined by adding to the belt width

- 6 inches (150 mm) for fabric belt
- 8 inches (200 mm) for steelcord belt

To this figure multiply by:

- 1.07 for 22 degree bias angle
- 1.05 for 17 degree bias angle

Dimensions A and B represent the outside platen dimensions. Scan down the list below until you arrive at a platen size that corresponds with your figures.

If the size you require is not listed below our sales department will be happy to recommend a suitable size.

Custom sizes, rectangular configurations and multiple platen arrangements are also available upon request.

A= Length of platen along the belt.

B= Width of platen across the belt on the bias.

C= Right angle dimension across the belt, plus edge overlap

D= Bias angle.

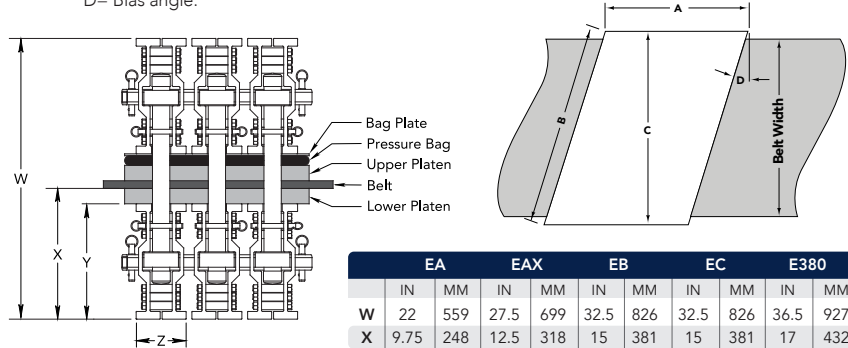

	EA		EAX		EB		EC		E380	
	IN	MM	IN	MM	IN	MM	IN	MM	IN	MM
W	22	559	27.5	699	32.5	826	32.5	826	36.5	927
X	9.75	248	12.5	318	15	381	15	381	17	432
Y	7.75	197	10.5	267	13	330	13	330	15	381
Z	7	178	7	178	6	152	6.5	165	6.5	165

The following is only a small sampling of Sectional vulcanizing presses from Almedex Canada. Contact us or your Almedex representative for more information. 100 PSI (7kg/cm²) units available for splicing fabric ply belting.

MODEL NUMBER	MAX BELT WIDTH		PLATEN DIMENSIONS						SPLICE LENGTH		SPANNER BARS				QTY BOLT/NUT ASSY.	MAIN COMPONENT WEIGHTS						APPROX. TOTAL WEIGHT	
			A		B		C				QTY	TYPE	LENGTH			PLATEN		BAR		WEIGHT			
			IN	MM	IN	MM	IN	MM					IN	MM		LBS	KG	LBS	KG	LBS	KG		
SVP 1930	24	610	19	480	30	760	28	705	13	330	2 sets	EA	42	1065	4	55	25	52	24	18	8	494	225
SVP 1937	30	760	19	480	37	940	34	870	13	330	2 sets	EA	49	1245	4	68	31	61	28	18	8	560	255
SVP 1943	36	915	19	480	43	1090	40	1015	13	330	2 sets	EA	55	1395	4	79	36	68	31	18	8	617	281
SVP 2643	36	915	26	660	43	1090	40	1015	20	510	3 sets	EA	55	1397	6	108	49	68	31	18	8	891	405
SVP 2843	36	915	28	710	43	1090	40	1015	22	560	3 sets	EA	55	1397	6	116	53	68	31	18	8	915	416
SVP 3343	36	915	33	840	43	1090	40	1015	27	685	4 sets	EA	55	1397	8	137	62	68	31	18	8	1149	522
SVP 3743	36	915	37	940	43	1090	40	1015	31	785	4 sets	EA	55	1397	8	153	70	68	31	18	8	1198	544
SVP 1950	42	1065	19	480	50	1270	46	1175	13	330	2 sets	EA	62	1574	4	92	42	77	35	18	8	683	311
SVP 2850	42	1065	28	710	50	1270	46	1180	22	560	3 sets	EA	62	1574	6	135	61	77	35	18	8	1014	461
SVP 3350	42	1065	33	840	50	1270	46	1180	27	685	4 sets	EA	62	1574	8	159	72	77	35	18	8	1274	579
SVP 4250	42	1065	42	1065	50	1270	46	1180	36	915	5 sets	EA	62	1574	10	202	92	77	35	18	8	1588	722
SVP 1956	48	1220	19	480	56	1420	52	1320	13	330	2 sets	EA	68	1727	4	103	47	84	38	18	8	740	336
SVP 2856	48	1220	28	710	56	1420	52	1320	22	560	3 sets	EA	68	1727	6	151	69	84	38	18	8	1098	499
SVP 3756	48	1220	37	940	56	1420	52	1320	31	785	4 sets	EA	68	1727	8	200	91	84	38	18	8	1441	655
SVP 4256	48	1220	42	1065	56	1420	52	1320	36	915	5 sets	EA	68	1727	10	227	103	84	38	18	8	1722	783
SVP 2658	48	1220	26	660	58	1475	54	1370	20	510	3 sets	EA	70	1778	6	145	66	87	39	18	8	1095	498
SVP 3358	48	1220	33	840	58	1475	54	1370	27	685	4 sets	EA	70	1778	8	185	84	87	39	18	8	1416	643
SVP 3758	48	1220	37	940	58	1475	54	1370	31	785	4 sets	EA	70	1778	8	207	94	87	39	18	8	1478	672
SVP 4558	48	1220	45	1140	58	1475	54	1370	39	990	5 sets	EA	70	1778	10	252	114	87	39	18	8	1814	824
SVP 2862	54	1370	28	710	62	1575	57	1460	22	560	3 sets	EA	74	1879	6	167	76	92	42	18	8	1183	538
SVP 3365	54	1370	33	840	65	1650	60	1530	27	685	4 sets	EA	77	1955	8	207	94	95	43	18	8	1540	700
SVP 3665	54	1370	36	915	65	1650	60	1530	30	760	4 sets	EA	77	1955	8	226	103	95	43	18	8	1592	723
SVP 4068	55	1395	40	1015	68	1725	63	1600	34	865	4 sets	EAX	80	2032	8	262	119	122	55	20	9	1914	870
SVP 1969	60	1525	19	480	69	1755	64	1625	13	330	2 sets	EA	81	2057	4	126	57	100	46	18	8	863	392
SVP 2469	60	1525	24	610	69	1750	64	1625	18	455	3 sets	EA	81	2057	6	160	73	100	46	18	8	1209	549
SVP 2871	60	1525	28	710	71	1800	66	1675	22	560	3 sets	EAX	83	2108	6	192	87	126	57	20	9	1461	664
SVP 3371	60	1525	33	840	71	1800	66	1675	27	685	4 sets	EA	83	2108	8	226	103	103	47	18	8	1646	748
SVP 3671	60	1525	36	915	71	1800	66	1675	30	760	4 sets	EAX	83	2108	8	246	112	126	57	20	9	1904	866
SVP 4471	60	1525	44	1115	71	1800	66	1675	38	965	5 sets	EA	83	2108	10	301	137	103	47	18	8	2095	952
SVP 4273	60	1525	42	1065	73	1850	68	1720	36	915	5 sets	EAX	85	2159	10	296	134	129	59	20	9	2360	1073
SVP 1984	72	1830	19	480	84	2135	78	1975	13	330	2 sets	EAX	96	2438	4	154	70	146	66	20	9	1121	509
SVP 2886	72	1830	28	710	86	2185	80	2030	22	560	3 sets	EAX	98	2489	6	232	106	149	68	20	9	1697	772
SVP 3386	72	1830	33	840	86	2185	80	2030	27	685	4 sets	EAX	98	2489	8	274	124	149	68	20	9	2148	976
SVP 3786	72	1830	37	940	86	2185	80	2030	31	785	4 sets	EAX	98	2489	8	307	139	149	68	20	9	2237	1017
SVP 2897	84	2135	28	710	97	2465	90	2285	22	560	3 sets	EAX	109	2768	6	262	119	166	75	20	9	1871	850



SVP Sectional Vulcanizing Press

PRODUCT SPECIFICATIONS:

200 psi (14kg/cm²) units available for splicing steelcord conveyor belting.

MODEL NUMBER	MAX BELT WIDTH		PLATEN DIMENSIONS						SPLICE LENGTH		SPANNER BARS				QTY BOLT/NUT ASSY.	MAIN COMPONENT WEIGHTS						APPROX. TOTAL WEIGHT	
			A		B		C				QTY	TYPE	LENGTH			PLATEN		BAR		WEIGHT			
			IN	MM	IN	MM	IN	MM					IN	MM		IN	MM	LBS	KG	LBS	KG		
SVP 2643	32	815	26	660	43	1090	40	1015	12	305	3 sets	EA	55	1397	6	108	49	68	31	18	8	1001	455
SVP 2843	32	815	28	710	43	1090	40	1015	14	355	3 sets	EA	55	1397	6	116	53	68	31	18	8	1025	466
SVP 3343	32	815	33	840	43	1090	40	1015	19	485	4 sets	EA	55	1397	8	137	62	68	31	18	8	1259	572
SVP 3743	32	815	37	940	43	1090	40	1015	23	585	4 sets	EA	55	1397	8	153	70	68	31	18	8	1308	594
SVP 2850	38	965	28	710	50	1270	46	1180	14	355	3 sets	EA	62	1574	6	135	61	77	35	18	8	1124	511
SVP 3350	38	965	33	840	50	1270	46	1180	19	485	4 sets	EA	62	1574	8	159	72	77	35	18	8	1384	629
SVP 4250	38	965	42	1065	50	1270	46	1180	28	710	5 sets	EA	62	1574	10	202	92	77	35	18	8	1698	772
SVP 2856	44	1120	28	710	56	1420	52	1320	14	355	3 sets	EAX	68	1727	6	151	69	103	47	20	9	1335	607
SVP 3756	44	1120	37	940	56	1420	52	1320	23	585	4 sets	EAX	68	1727	8	200	91	103	47	20	9	1719	781
SVP 4256	44	1120	42	1065	56	1420	52	1320	28	710	5 sets	EAX	68	1727	10	227	103	103	47	20	9	2043	928
SVP 2658	46	1170	26	660	58	1475	54	1370	12	305	3 sets	EAX	70	1778	6	145	66	106	48	20	9	1335	607
SVP 3358	46	1170	33	840	58	1475	54	1370	19	485	4 sets	EAX	70	1778	8	185	84	106	48	20	9	1698	772
SVP 3758	46	1170	37	940	58	1475	54	1370	23	585	4 sets	EAX	70	1778	8	207	94	106	48	20	9	1761	800
SVP 4558	46	1170	45	1140	58	1475	54	1370	31	785	5 sets	EAX	70	1778	10	252	114	106	48	20	9	2140	973
SVP 2862	50	1270	28	710	62	1575	57	1460	14	355	3 sets	EAX	74	1879	6	167	76	112	51	20	9	1429	650
SVP 3365	52	1320	33	840	65	1650	60	1530	19	485	4 sets	EAX	77	1955	8	207	94	117	53	20	9	1838	836
SVP 3665	52	1320	36	915	65	1650	60	1530	22	560	4 sets	EAX	77	1955	8	226	103	117	53	20	9	1890	859
SVP 4068	55	1395	40	1015	68	1725	63	1600	26	660	5 sets	EB	80	2032	10	262	119	134	61	22	10	2457	1117
SVP 2469	56	1420	24	610	69	1750	64	1625	10	255	3 sets	EAX	81	2057	6	160	73	123	56	20	9	1467	667
SVP 2871	58	1470	28	710	71	1800	66	1675	14	355	3 sets	EB	83	2108	6	192	87	139	63	22	10	1663	756
SVP 3371	58	1470	33	840	71	1800	66	1675	19	485	4 sets	EAX	83	2108	8	226	103	126	57	20	9	1958	890
SVP 3671	58	1470	36	915	71	1800	66	1675	22	560	5 sets	EB	83	2108	10	246	112	139	63	22	10	2461	1118
SVP 4471	58	1470	44	1115	71	1800	66	1675	30	765	6 sets	EB	83	2108	12	301	137	139	63	22	10	2934	1334
SVP 4273	60	1525	42	1065	73	1850	68	1720	28	710	6 sets	EB	85	2159	12	296	134	143	65	22	10	2957	1344
SVP 2886	72	1830	28	710	86	2185	80	2025	14	355	4 sets	EB	98	2489	8	232	106	165	75	22	10	2288	1040
SVP 3386	72	1830	33	840	86	2185	80	2025	19	485	4 sets	EC	100	2540	8	274	124	248	113	36	16	3181	1446
SVP 3786	72	1830	37	940	86	2185	80	2025	23	585	5 sets	EB	98	2489	10	307	139	165	75	22	10	2863	1301
SVP 2897	82	2085	28	710	97	2465	90	2285	14	355	3 sets	E380	111	2819	6	262	119	320	145	41	19	3033	1379

Specifications are approximate and subject to change without notice. Integral cooling standard on all units. Total weights include electrical control panel, cable sets and set-up templates for all models. Temperature adjustable between 200 - 325 deg. F, (93 - 163 C). Sectional vulcanizers are built on a 22 degree bias with a left hand lead. Custom sizes, rectangular configurations and multiple platen arrangements available upon request. 200 psi models include fluid pressure pump and reservoir unit, model HPP20-4, (mandatory for operating pressures above 100 psi/7 kg/cm²).